

ENT examination and diagnosis unit

ENT UNIT

이비인후과 진단장비 카탈로그 ver.2

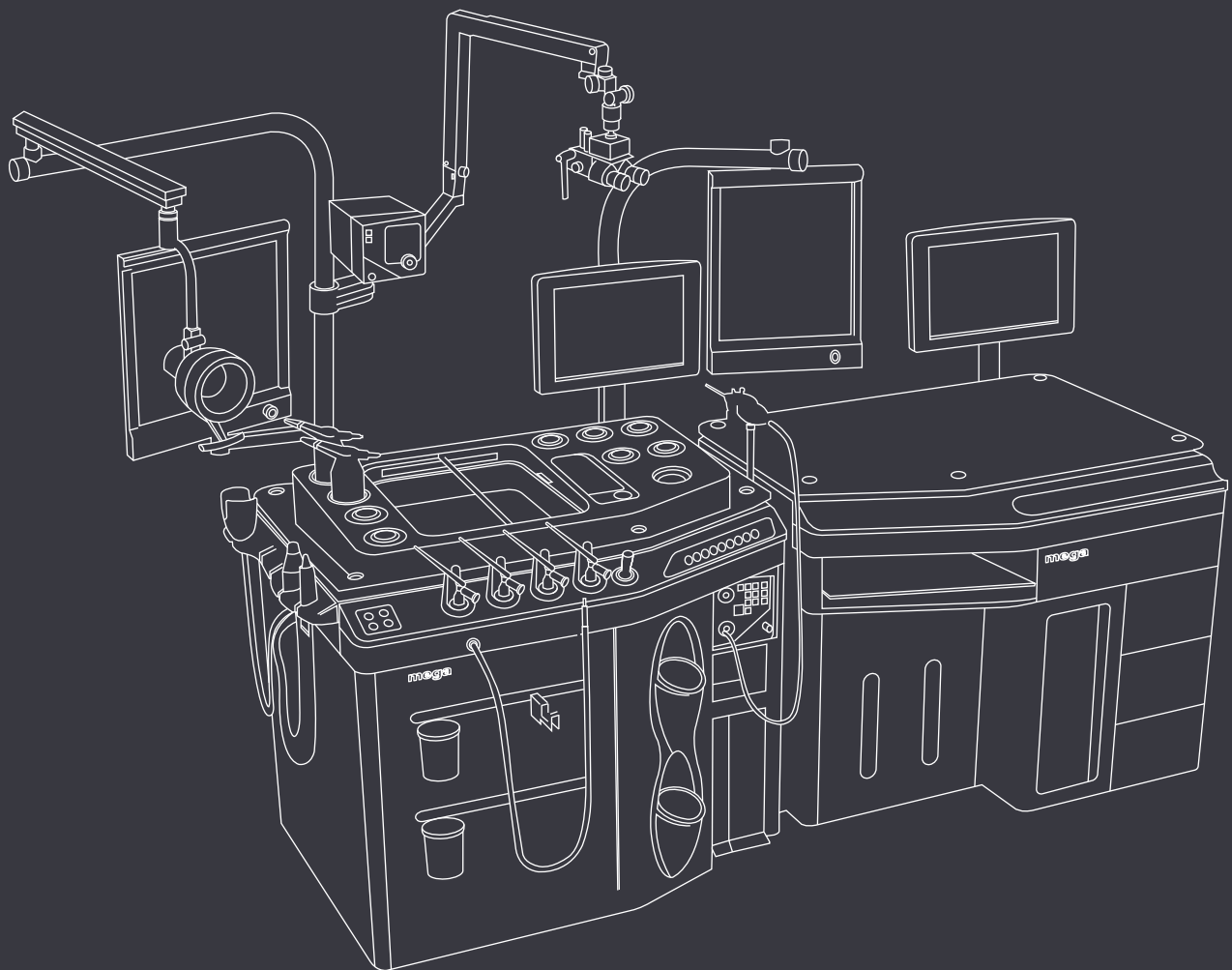

NET-3000A



Various Options



Step Type Trash Can



Instrument Container
w/ Heating



Instrument Container
w/ UV Sterilizer



Keyboard Holder



Main & Sub
Suction Bottle

Features

- Ergonomic design for user's convenience
- Whole-in-one workstation
- Various instrument containers with sterilizing and heating
- Hygienic saline spray irrigation
- Various useful options
- Central Water Supply, Auto-Drainage System (Option)

Specifications

Compressor pump	1.7kg/cm ²
Vacuum pump	600 - 740mmHg(Max)
Main suction bottle	3,000cc
Sub suction bottle	3,000cc
Power consumption	600 - 1400W
Voltage	110/220V
Frequency	50/60Hz
Weight	250kg
Dimensions (W x D x H)	1,900 x 780 x 820 mm

Standard Accessories

Straight spray	3
Curved spray	1
Suction bottle	2
Gauze container	1
Waste receptacle	3
Medical bottle	6
Instrument tray	3
Anti-Fog device	1
Rotation keyboard table	1
Pen light	1
Step type trash can	1
Tissue paper container	1
Instrument container w/ UV sterilizer	1
Instrument container w/ heating	1

Optional Accessories

CWS/AD system	1
View box	1
LCD monitor	1
Endoscopy system	1
Microscope	1
Ear irrigation system	1
Illumination	1
Powder spray	1
Ear dryer	1
Eustacure	1
Operating otoscope	1
Telescope sterilizer	1
Head light	1

ENT UNIT

NET-3000C



Features

- Ergonomic design for user's convenience
- Whole-in-one workstation
- Various useful options
- Central Water Supply, Auto-Drainage System (Option)

Specifications

Compressor pump	0.9 - 2.0kg/cm ²
Vacuum pump	600 - 740mmHg
Main suction bottle	2,000 - 3,000cc
Sub suction bottle	500 - 1,000cc
Power consumption	600 - 1,400W
Voltage	110/220V
Frequency	50/60Hz
Weight	185kg
Dimensions (W x D x H)	1,800 x 690 x 830 mm

Standard Accessories

Straight spray	3
Curved spray	1
Suction	2
Gauze container	1
Waste receptacle	3
Medicine bottle	6
Instrument tray	3
Anti-Fog device	1
Keyboard table	1

Optional Accessories

CWS/AD system	1
Endoscopy system	1
LCD monitor	1
View box	1
Microscope	1
Powder spray	1
Illumination	1
Head light	1
Ear irrigation system	1
Ear dryer	1
Eustacure	1
Telescope sterilizer	1
Wireless pen light	1
Operating otoscope	1

NET-600A



Features

- Various useful options
- Central Water Supply, Auto-Drainage System (Option)
- Large and sufficient storage cart

Specifications

Compressor pump	0.9 - 2.0kg/cm ²
Vacuum pump	600 - 680mmHg(Max)
Main Suction bottle	2,000 - 3,000cc
Sub Suction bottle	500 - 1,000cc
Anti-Fog device	400W
Power consumption	1,000W (Max)
Voltage	110V/220V
Frequency	50/60Hz
Weight	130Kg
Dimensions (W x D x H)	1,295 x 445 x 865 mm
Chart table size	435 x 445 x 865 mm

Standard Accessories

Straight spray	2~3
Suction	1~2
Gauze container	2
Waste receptacle	2
Medicine bottle	2~5
Instrument tray	2
Anti-Fog device	1
Pen light	1

Optional Accessories

CWS/AD system	1
Endoscopy system	1
LCD monitor	1
Nasal&Ear irrigation	1
Powder spray	1
Chart table	1
Ear dryer	1
Eustacure	1
Operating otoscope	1
Head light	1
Illumination	1
View box	1
Telescope sterilizer	1



NET-600B



Features

- Ergonomic design with simple square shape
- Various useful options

Specifications

Compressor pump	0.9 - 2.0kg/cm ²
Vacuum pump	600 - 680mmHg(Max)
Anti-Fog device	400W
Power consumption	1,000W(Max)
Voltage	110/220V
Frequency	50/60Hz
Weight	115kg
Dimensions (W x D x H)	920 x 535 x 890 mm

Standard Accessories

Straight spray	2~3
Suction	1~2
Gauze container	5
Waste receptacle	2
Medicine bottle	2~5
Instrument tray	3
Anti-Fog device	1
Pen light	1

Optional Accessories

Powder spray	1
Visual system	1
Head light	1

NET-600C



Features

- Soft and sophisticated spray
- Ergonomic design with compact size

Specifications

Compressor pump	0.9 - 2.0kg/cm ²
Vacuum pump	600 - 680mmHg(Max)
Anti-Fog device	400W
Power consumption	1,000W
Voltage	110/220V
Frequency	50/60Hz
Weight	95kg
Dimensions (W x D x H)	800 x 590 x 900 mm

Standard Accessories

Straight spray	3
Suction	1
Gauze container	3
Waste receptacle	2
Medicine bottle	4
Anti-Fog device	1
Pen light	1

Optional Accessories

Endoscopy system	1
LCD monitor	1
View box	1

NET-1100



NET-1100 User manual

Features

- Best compacted size
- Portable type
- High quality endurance & noiseless suction motor
- Various useful options
- Well-designed instrument cart (Option)

Specifications

Compressor pump	0.9 - 2.0kg/cm ²
Vacuum pump	600 - 680mmHg
Anti-Fog device	400W
Power consumption	850W
Voltage	110/220V
Frequency	50/60Hz
Weight	80kg (Full set)
Dimensions (W x D x H)	Full Setting : 1,050 x 590 x 1,250mm Main : 500 x 422 x 934mm Tray : 500 x 500 x 975mm

Standard Accessories

Straight spray	2
Suction	1
Anti-Fog device	2
Medical bottle	1
Heating system	1
Telescope holder	2

Optional Accessories

Head light	1
Endoscopy system	1
LCD monitor	1
Ear irrigation bottle w/ funnel	1
Telescope sterilizer	1
Operation otoscope	1
Head light	1
Eustacure	1
Powder spray	1
Instrument cart	1



NET-280B on unit



Various options for NET-1100
Operating otoscope Eustacure

NET-1500 Series



NET-1500E



NET-1500D



NET-1500A, B, C

Specifications

	NET-1500E	NET-1500D	NET-1500A,B,C
Backrest inclination	0~30°	0~95°	0~95°
Base diameter	550mm	550mm	580mm
Up-Down stroke	500 ~ 800mm	550 ~ 850mm	520 ~ 820mm
Rotating angle	360°	360°	360°
Adjustable headrest (Manual)	Option	Standard	Standard
Rotating armrest/angle (360°)	Option	Standard	Standard
Adjustment	Hydraulic valve system (1 pair)	Hydraulic valve system (2:2 pairs)	Hydraulic valve system (3:3 pairs)
- Up/Down	Auto	Auto	Auto
- Forward/Backward	Manual	Auto	Auto
- Rotation auto brake system	-	-	A type only
Seat material	Artificial Leather	Artificial Leather	Artificial Leather
Color	Beige Blue / Beige Gray	Gray	Gray
Power consumption	350W	500W	550 W
Voltage	220V		
Frequency	50/60 Hz		
Dimensions (W x D x H) (mm)	780 x 585 x 1,180	620 x 849 x 1,380	740 x 600 x 1,340
Weight	75kg	90kg	95kg
Standard accessories	Foot paddle	Foot paddle	Foot paddle

ENT Head Light

MHL-002



Features

- Ultra bright LED light with high density LED
- Easy to adjust head strap & angle
- Extensive LED lifetime(more than 50,000 hrs)
- More than 4 hours of continuous use
- Easy to recharge
- An additional astral LED lamp(Optional)
- Attachable loupe(Optional)

Optional Accessories



Specifications

Main body	
Illumination	15,000lx (at 25cm working distance)
Color temperature	6,000kelvin
Max LED operation life	50,000h
Weight	119g
Headband size	534 - 638mm
Battery Module	
Operation time	4h
Recharge	800times
Output	3.7V
Capacity	2,200 mAh
Type	Li-ion (Built-in protected circuit module)
Weight	69g
Charger	
Input	AC 100 - 240V, 50/60Hz
Output	DC 4.2V/ 750mA
Charging time	4h

Standard Accessories

Main body	1
Headband	1
Battery pack	1
Charger	1
Operator's manual	1

Optional Accessories

Astral lamp	1
Loupe	1.5(1ea), 3.5(1ea)
Battery module	1

Micro-100



Specifications

Objective lens(standard)	F=250mm
Magnification	X3 , X5, X8
Working distance	190mm
Bulb	12V / 100W
Type	Stand type, Unit attach type
Parameter of Binocular tube	
Inclined binocular tubes	45▲
Diopter adjustment range	÷ 6D
Pupil distance range	50mm// 70m
Height of eyecups	18mm
Parameter of illumination	
6 + 0 Coaxial illumination	30,000lx or up
Maximum intensity	
Parameter of position adjustment	
Maximum stretching radius of arm	870mm
Vertical movement range (from floor to front surface of big objective)	700//1,100mm
Range of fine focusing adjustment	30mm
Parameter of Electric	
Input voltage	AC 110/220V 50Hz
Input power	120VA
Voltage	220V
Frequency	60Hz
Weight	40kg
Dimension (W x D x H)	180 x 60 x 170 mm

ENT Accessories



Ear Irrigation(Suction)



Ear Irrigation(Spray)



Nasal Irrigation



Powder Spray



Eustacure



Ear Dryer



Operating Otoscope



Telescope Sterilizer
- Rigid 2
- Rigid 2 + Flexible 1



New Suction gun



Suction tip(disposable) - 100ea, 1box



4.00 ear tip(disposable) - 25ea, 1set
2.70 ear tip(disposable) - 25ea, 1set



Spray tip(disposable) - 100ea, 1box



(주)메가메디칼

서울사무소
Seoul office

서울시 강남구 봉은사로 439 CC빌딩 5층 (삼성동 44-12)
5th Fl., CC Bldg. 439, Bongeunsa-ro, Gangnam-gu, Seoul, KOREA

원주본사
Head office

강원도 원주시 문막읍 동화공단로 110-1 (동화 첨단의료기단지 내)
110-1, Donghwagongdan-ro, Munmak-eup, Wonju-si, Gangwon-do, KOREA

고객센터
Call Center

TEL : **1588-4493**
T. +82-2-3662-4493 F. +82-2-3661-0120